

# Dynamic Economic Dispatch for 150 kV Sulsebar Power Generation Systems Using Artificial Bee Colony Algorithm

*by Ys Akil*

---

**Submission date:** 07-Sep-2022 05:14PM (UTC+0700)

**Submission ID:** 1894291492

**File name:** DED\_150\_kV\_Sulsebar\_uisng\_ABC\_Algorithm.pdf (510.42K)

**Word count:** 4123

**Character count:** 19867

# Dynamic Economic Dispatch for 150 kV Sulselbar Power Generation Systems Using Artificial Bee Colony Algorithm

Haripuddin<sup>1,2</sup>, Ansar Suyuti<sup>1</sup>

<sup>1</sup>Electrical Engineering Department, Hasanuddin University

<sup>2</sup>Electrical Engineering Department, Makassar State University

Makassar, Indonesia

haripuddin@unm.ac.id, asuyuti06@yahoo.com,

Sri Mawar Said<sup>1</sup>, Yusri Syam Akil<sup>1</sup>

<sup>1</sup>Electrical Engineering Department, Hasanuddin University

Makassar, Indonesia

srinawarsaid@yahoo.com, yusakil@unhas.ac.id

**Abstract**— Managing power generation is very important in the process of distributing electrical energy to consumers to get optimal power generation in the system with minimum cost. In this study, an Artificial Bee Colony algorithm is proposed to get the best economic dispatch solution for the 150 kV Sulselbar electric system in Indonesia by considering losses, generation limits and ramp rate for each unit. Simulation results from the same system are compared with the Lagrange method which only considers the generator power limit. Besides that, voltage stability of the system is also evaluated using the L index including the loading margin on buses which are considered weak. Results have shown the proposed method (Artificial Bee Colony algorithm) is able to provide the best solution for dynamic economic dispatch to the observed system.

**Keywords**—Dynamic economic dispatch, Sulselbar electric system, voltage stability, L index stability, loading margin, Artificial Bee Colony algorithm.

## I. INTRODUCTION

In many places, locations of power plants in an electric system have different distances from load center and their fuel costs can be also different [1]. Therefore, it is important to manage power generation in meeting load for a better operation which is known as economic dispatch (ED). In general, ED can be categorized as classical economic dispatch (CED) and dynamic economic dispatch (DED). Basically, ED has the purpose to determine optimal power output for generation units to meet electricity demand by meeting operating limits under a period of power distribution, and it is recognized as CED where line security limits are ignored [2].

The main purpose of a power engineer is to design an electric power generation system that is reliable, optimal and efficient at minimum production and operating costs [3]. As in [4], the main purpose of the use of electricity is to provide reliable and high-quality power supplies to customers at the lowest cost while operating to meet possible limits and constraints on generating units and environmental considerations. Meanwhile in [5], conducting power system optimization is very important for better power operation that

helps in planning and managing a power system with good quality. In the electric power system, quality, reliability, continuously, safety and stability is very important [6]. As in [7], system stability has a significant effect when interconnected electricity networks are developed.

In Indonesia, electricity energy is mainly generated from thermal power plants which used fossil fuels such as coal, petroleum and natural gas. However, the availability of fossil fuels in the world, especially in Indonesia tends to decrease by time. As an impact depletion of the fuels, it will increase fuel price and affect production costs for each generator unit in the electric system during its operation. Besides that, considering the increasing electricity load, it will increase the usage of fuel and certainly production cost will be higher for power plants. Therefore, an optimization study needs to be done to reduce the production of electricity cost by finding optimal power generation for each thermal power plant in the system. This study proposes the Artificial Bee Colony algorithm to solve the DED problem for Sulselbar electric system in Indonesia.

## II. DYNAMIC ECONOMIC DISPATCH

The dynamic economic dispatch (DED) is scheduling that has load predictive capabilities for a period of time by coordinating predictions of load changes with the response rate capability of the generating unit [8]. The dynamic economic dispatch (DED) of thermal power plants consider things such as valve point effects, ramp rate limits, emissions and integration of renewable energy generation. However in this paper, the researcher only considers generator power limits and generator ramp rate limits as preliminary study. The total cost of this system is the total cost of each generation unit. An important limitation on this operating system is the amount of output power generated must be the same as the serves load demand [9].

### A. Thermal Power Plants

The fundamental parameter that needs to be considered for the problem of operating economically a power generation

system is regulating the input-output of a thermal power plant system [8].

The input-output characteristics of the ideal thermal power plant are illustrated by a nonlinear curve. The widely used input-output characteristics of thermal power plant units are quadratic functions. The input and output characteristics of the generating unit indicate that the output power is limited by the minimum and maximum capacity of the generating unit, namely:

$$P_{min} \leq P \leq P_{max} \quad (1)$$

The input to the thermal power plant is measured in Btu/h (Fuel Input) or \$/h (Cost,  $C_t$ ) and the output is measured in MW [1]. The  $C_t$  cost function is assumed to be known at each generating unit. The problem is to find the actual cost of generation so that the minimum objective function (total production cost) can be formulated in the form of equations: [1]

$$C_t = \sum_{i=1}^{n_g} C_i \quad (2)$$

$$C_i = \sum_{i=1}^{n_g} \alpha_i + \beta_i P_i + \gamma_i P_i^2 \quad (3)$$

where  $C_t$  is the total generation cost,  $C_i$  is the generation cost of each generator,  $P_i$  is the amount of generating capacity of each generation unit and  $\alpha_i$ ,  $\beta_i$ ,  $\gamma_i$  is the cost coefficient of each generation unit.

The most efficient generators in the system do not guarantee minimum costs because they may be located in areas where fuel costs are high. Generators that are located far from load centers, transmission losses are considered more and hence the power plant may become uneconomical. Therefore, the problem is to determine the generation of electricity from different power plants so that the total operating costs are minimal and that is why the operating costs of this electricity generation play an important role in economic dispatch [1].

#### B. Fuel Cost Function

The function of fuel costs in thermal generators is a quadratic function of the real power at the generator. The input-output relationship curve H (MBtu/h) will be obtained by multiplying the fuel (IDR/MBtu) into a function  $f_i(P_i)$  in (\$/h) [8].

$$\text{Min } F = \sum_{i=1}^N F_i P_i = \sum_{i=1}^N (a_i P_i^2 + b_i P_i + c_i) \quad (4)$$

where:

$F$  = total of fuel costs

$F_i P_i$  = fuel cost of generator- $i$

$P_i$  = actual generator of unit  $i$

$a_i, b_i, c_i$  = coefficients of cost

$N$  = total number of generators

#### C. Transmission Line Losses

Power plant centers and loads are generally connected in scenarios that are geographically distributed. Thus, transmission network losses must be taken into account to achieve economic scheduling correctly. Network losses are the function of power injection at each node, where the network losses of the actual power system  $P_L$  is expressed using the coefficient  $B$  [1], [10], [11] as follows:

$$P_L = \sum_{i=1}^n \sum_{j=1}^n P_i B_{ij} P_j + \sum_{i=1}^n B_{0i} P_i + B_{00} \quad (5)$$

where  $i$  is the number of generators,  $j$  is the number of buses in the system,  $B_{ij}$  is the  $ij$  element of the square matrix coefficient,  $B_{0i}$  is the  $i$  element of the loss of the matrix coefficient and  $B_{00}$  is the loss coefficient constant.

#### D. Generator Ramp Rate Limits

The ramp rate limits are the rate of change in output power per unit time or the response rate of the generator [8]. The ramp rate limit is used to prevent unwanted effects due to the dynamics of rapid changes and exceed the generator's ability. This limitation is important when carried out scheduling generators in a period of time so that it will affect the limit of generator units for the next time.

$$P_{min,i}^t = \max(P_{min,i}, P_i^{t-1} - DR_i) \text{ and} \\ P_{max,i}^t = \min(P_{max,i}, P_i^{t-1} + UR_i) \quad (6)$$

where  $P_{min,i}^t$  is the minimum limit of the generator- $i$  at time  $t$  will be the maximum of the design value of the minimum generator limit  $P_{min,i}$  or output of the generator- $i$  at time  $t-1$  ( $P_i^{t-1}$ ) is reduced by the rate of descending value of generator- $i$  ( $DR_i$ ) is the maximum limit of the generator- $i$  at time  $t$  will be the minimum of the design value of the maximum generator limit  $P_{max,i}$  or output of the generator- $i$  at time  $t-1$  ( $P_i^{t-1}$ ) added by the rate of ascending value of generator- $i$  ( $UR_i$ ). This generator ramp rate limit appears because of the minimum and maximum limits of the generator so that the equation for the generator ramp rate can also be written in the form of [4]:

$$p_i(t) - p_i(t-1) \leq UR_i \\ p_i(t-1) - p_i(t) \leq DR_i \quad (7)$$

### III. ARTIFICIAL BEE COLONY (ABC) ALGORITHM

The ABC algorithm is introduced to provide solutions to optimization problems with complex optimization constraints [8]. In the ABC algorithm, the colony of bees consists of three groups of bees, namely recruited bees, onlooker bees, and scout bees. The first half of the colony consisted of recruited bees and the second half was onlooker bees. For each food source, there is only one worker bee. In other words, the number of worker bees equals the number of food sources around the nest. Three control parameters are used in the ABC algorithm [12], namely:

1. The number of food sources that are equal to the number of recruited bees or onlooker bees (SN), determines the number of potential power solutions calculated in one iteration
2. The boundary-value is the limit value of the exploration of the power value of a new solution, and
3. The maximum number of cycles is the value of many repetitions to get the minimum solution value.

In this study, researchers used an Artificial Bee Colony algorithm to solve the dynamic economic dispatch in the 150 kV Sulsebar power generation system.

#### A. Initialization Stage

In the initialization stage, each generator has an active power limit of  $P_{max}$  and  $P_{min}$ . This initialization makes the

initial position of the colony randomly that is output power value  $P_j$ .

**B. Recruited Bee Phase**

The recruited bees will determine the value of power obtained from the previous power value by finding the power value around it (8).

$$P_{ij}^{new} = P_{ij}^{old} + \phi_{ij} \cdot (P_{ij}^{old} - P_{kj}) \tag{8}$$

where  $\phi_{ij}$  is a random value between [-1,1]. Then, new power values will be evaluated by calculating fitness values from the objective function.

**C. Onlooker Bee Phase**

The onlooker bees will evaluate the best  $P_{ij}$  power value from the recruited bees and then calculate the best fitness value.

**D. Scout Bee Phase**

The best value of power obtained in the onlooker bees phase will be evaluated the value limit and if fulfilled it will be the best fitness value. Flowchart of the ABC algorithm for dynamic economic dispatch show in Fig. 1.



Fig.1 Flowchart of the ABC algorithm for dynamic economic dispatch

**IV. RESULTS**

The test data was carried out using real generation and load data for the 150 kV Suselbar power generation system on December 4, 2017 at 7:30 pm when a peak load occurs as in [13]. In the one-line diagram (Fig. 2) of the 150 kV Suselbar power generation system, there are 9 generator buses. But in this study, testing was carried out using only 7

bus generators, namely the bus Tello, bus Balusu, bus Tallasa, bus Punagaya, bus Pare-Pare, bus Sengkang, and bus Palopo, while the other 2 buses were not operated at that time such as bus Sungguminasa and bus Bakaru. Then, fuel cost function and generator power constraint of the 150 kV Suselbar thermal power generation systems as in [14] are shown in Table 1.

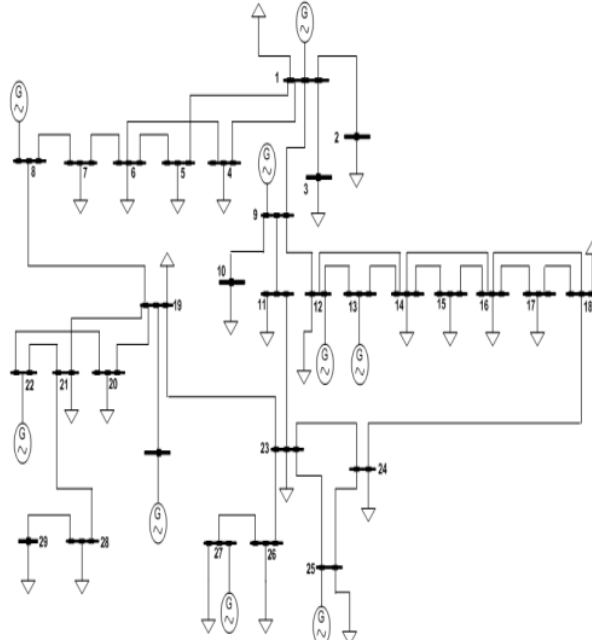

Fig. 2 One Line Diagram of 150 kV Suselbar Thermal Power Generation Systems.

bus 1 = Tello , bus 8 = Balusu, bus 9 = Sungguminasa  
 bus 12 = Tallasa , bus 13 = Punagaya , bus 19 = Pare-Pare  
 bus 22 = Bakaru , bus 25 = Sengkang , bus 27 = Palopo

Table 1. The fuel cost function {(IDR/hour)x1000} and generator power limits (MW) of the 150 kV Suselbar thermal power generation systems

Unit	Fuel Cost Function (IDR/hour)x1000	$P_{min}$ (MW)	$P_{max}$ (MW)
1	$1.3736e-12+2240.9P_1+7.1332e-11(P_1)^2$	2	8
2	$-2.4144e-14+427.4 P_2+1.1182e-11(P_2)^2$	9.68	38.73
3	$-3.6365e-14+1917.8P_3+4.5984e-11(P_3)^2$	5	8
4	$6.346e-15+432.75P_4+1.9212e-10(P_4)^2$	55.59	222.35
5	$-2.5302e-14+1908.44P_5+1.8497e-11(P_5)^2$	15	60
6	$-4.7539e-15+427.78P_6+1.0608e-10(P_6)^2$	54.88	219.5
7	$1.587e-13+2634.3P_7+1.3227e-11(P_7)^2$	1.25	5

The result of the cost comparison after optimization of the 150 kV Suselbar thermal power generation systems using the Lagrange method and ABC algorithm is shown in Table 2 and the ABC convergence graph of total generation costs for the generator power limit is shown in Fig. 3 with computational time is 216.09 seconds, the duration of this computation is because the evaluation of objective functions by calculating active power constraints, equality constraints, inequality

constraints, and power flows. Then, the graph of generation cost from each generator with generator power constraint is shown in Fig. 4 and the voltage profile graph and L index stability are shown in Fig. 5. While Table 3 shows the calculation results of the L index stability and voltage.

Table 2. The cost comparison after optimization of the 150 kV Sulsebar thermal power generation systems using the Lagrange method and Artificial Bee Colony

Bus Name	Lagrange Method		ABC Algorithm	
	EP* (MW)	Cost (IDR/hour)x 1000	EP* (MW)	Cost (IDR/hour)x 1000
Tello	8	17,927.200	8	17,927.200
Balusu	22.93	9,800.282	22.93	9,800.282
Tallasa	8	15,342.400	8	15,342.400
Punagaya	250.921	108,586.248	250.719	108,498.823
Pare-Pare	51.1	97,521.284	51.1	97,521.284
Sengkang	242.67	103,809.373	242.67	103,809.373
Palopo	5	13,171.500	5	13,171.500
Total	588.62	366,158.290	588.44	366,070.86
Losses (MW)	23.471		23.269	
The difference in costs (IDR/hour)	87,430			

EP\*=Electricity production in peak hour at 7.30 pm

Table 3. The calculation results of the L index stability and voltage

Bus Number	$L_j$	Voltage (pu)	Bus Number	$L_j$	Voltage (pu)
2	0.0133	0.9956	16	0.054	0.9684
3	0.0819	0.9569	17	0.074	0.9599
4	0.0086	0.9979	18	0.084	0.9558
5	0.0226	0.9908	20	0.0162	0.992
6	0.0162	0.9951	21	0.0226	0.991
7	0.0128	0.9967	22	0.0198	0.9919
9	0.0226	0.9908	23	0.0402	0.9706
10	0.0297	0.9805	24	0.0681	0.9635
11	0.0681	0.9643	26	0.0879	0.9489
14	0.0096	0.9976	28	0.0396	0.9741
15	0.0266	0.9824	29	0.0404	0.9687

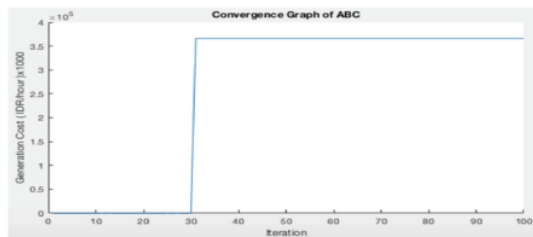

Fig. 3 ABC convergence graph of total generation costs for generator power constraint

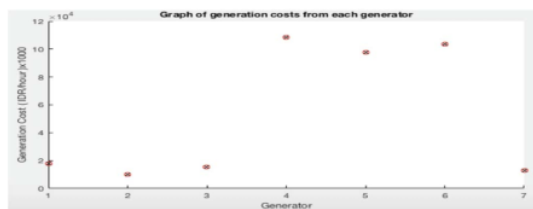

Fig.4 Graph of generation costs for each generator with generator power constraint

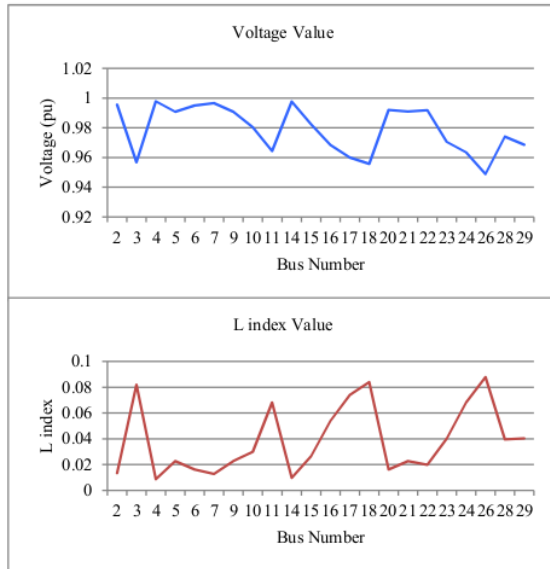

Fig. 5 Voltage profile graph and L index stability with generator power constraint

Table 2 shows the optimization of the fuel cost comparison of the ABC algorithm and the Lagrange method for 7 thermal generating units that supply electrical energy to the load. From Table 2, it can be seen that there are fuel cost savings of 87,430 IDR/hour, this occurs because of the difference in active power generated at the bus Punagaya of 0.202 MW from 250.921 MW to 250.719 MW. Likewise, with network losses, it can be seen that there was a decrease in losses on the system of 0.202 MW from 23.471 MW to 23.269 MW. Table 3 and Fig. 5 show that the largest L index value is obtained on buses 3, 18 and 26 of 0.0819, 0.084 and 0.0879 with a voltage of 0.9569, 0.9558 and 0.9489 pu. This shows that the voltage conditions on buses 26 overcome instability condition and considered critical bus in the system.

Subsequent testing is carried out on two system constraints namely generator power limits and generator ramp rate limits. Table 4 shows the function of fuel costs, generator power limits, and generator ramp rates.

Table 4. The fuel cost function {(IDR/hour)x1000}, generator power limits (MW) and generator ramp rate limits (MW/h) of the 150 kV Sulsebar thermal power generation systems

Unit	Fuel Cost Function (IDR/hour)x1000	$P_{min}$ (MW)	$P_{max}$ (MW)	UR (MW/h)	DR (MW/h)
1	$1.3736e-12+2240.9P_1+7.1332e-11(P_1)^2$	2	8	480	480
2	$-2.4144e-14+427.4P_2-1.1182e-11(P_2)^2$	9.68	38.73	180	180
3	$-3.6365e-14+1917.8P_3-4.5984e-11(P_3)^2$	5	8	480	480
4	$6.346e-15+432.75P_4+1.9212e-10(P_4)^2$	55.59	222.35	180	180
5	$-2.5302e-14+1908.44P_5+1.8497e-11(P_5)^2$	15	60	480	480

6	$-4.7539e-15+427.78P_6-1.0608e-10(P_6)^2$	54.88	219.5	600	600
7	$1.587e-13+2634.3P_7+1.3227e-11(P_7)^2$	1.25	5	480	480

The results of the optimization of the 150 kV Sulselbar thermal power generation system for generator power limit and generators ramp rate limit using the ABC algorithm are shown in Table 5 and ABC convergence graph of total generation costs for generator power and generator ramp rate constraint is shown in Fig. 6 with computational time is 218.82 seconds, Graph of generation costs for each generator with generator power and generator ramp rate constraint are shown in Fig. 7 and voltage profile graph and L index stability with generator power and ramp rate constraint after optimization are shown in Fig. 8.

Table 5. The results of optimization of the 150 kV Sulselbar thermal power generation systems using ABC algorithm for generator power and ramp rate limits

Bus Name	Artificial Bee Colony Algorithm	
	EP* (MW)	Cost (IDR/hour)x1000
Tello	8	17,927.200
Balusu	22.93	9,800.282
Tallasa	8	15,342.400
Punagaya	250.832	108,547.646
Pare-Pare	51.1	97,521.284
Sengkang	242.67	103,809.373
Palopo	5	13,171.500
Total	588.53	366,119.68
Losses (MW)	23.471	

EP\*=Electricity production in peak hour at 7.30 pm

Table 6. The calculation results of the L index stability and voltage

Bus Number	$L_j$	Voltage (pu)	Bus Number	$L_j$	Voltage (pu)
2	0.0749	0.9434	16	0.0236	0.9604
3	0.0884	0.9021	17	0.0295	0.9567
4	0.0404	0.9475	18	0.0274	0.9588
5	0.0766	0.9413	20	0.0142	0.9717
6	0.0551	0.9466	21	0.0177	0.9705
7	0.0305	0.9559	22	0.0169	0.9715
9	0.0712	0.9446	23	0.0107	0.9824
10	0.0856	0.9337	24	0.0094	0.9888
11	0.0222	0.9655	26	0.0838	0.9398
14	0.0135	0.9778	28	0.039	0.953
15	0.0219	0.9681	29	0.0435	0.9474

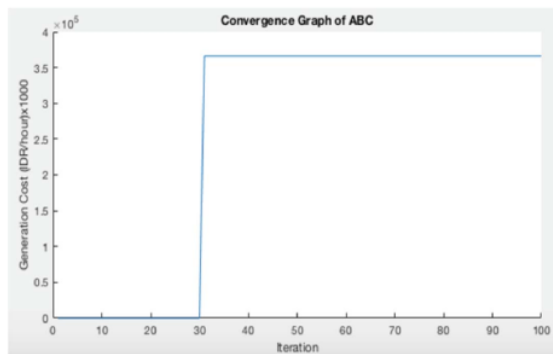

Fig. 6 ABC convergence graph of total generation costs for generator power and generator ramp rate constraint

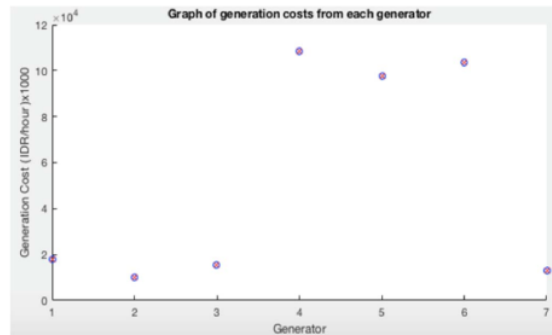

Fig. 7 Graph of generation costs for each generator with generator power and generator ramp rate constraint

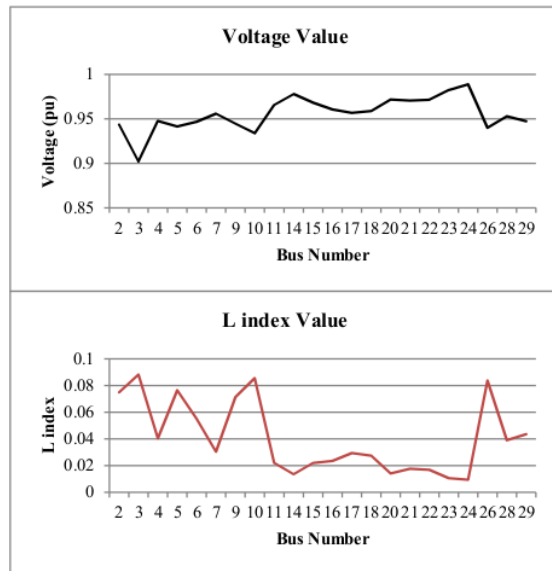

Fig. 8 Voltage profile graph and L index stability with generator power and ramp rate constraint

Table 5 previously shows the results of fuel cost optimization using the ABC algorithm for 7 units of 150 kV sulselbar thermal power generation systems that supply electrical energy to the load. From Table 5, it can be seen that the fuel costs obtained after optimization by considering generator power limits and ramp rate generators are 366,119,680 IDR/hour with a total optimal power generation generated at 588.53 MW and network losses of 23.471 MW. Table 6 and Fig. 8 show that the largest L index value is obtained on buses 26, 10 and 3 of 0.0838, 0.0856 and 0.0884 with the voltage of 0.9398, 0.9337 and 0.9021 pu. This shows that the voltage conditions on buses 26, 10 and 3 overcome instability condition and become critical buses in the system, so also on buses 2, 4, 5, 6, 9, and 29 are buses that are quite

critical because the voltage value is below 0.95 pu that is the nominal voltage allowed in the system. Then loading is carried out on bus 3 until the load reaches 284 MW to approach the critical point where the voltage on the bus nearly collapse with an L index stability value of 0.9357 with a voltage of 0.5333 pu, the critical point is achieved by loading 285 MW when the voltage collapses with the index value L stability of 0.9853 with a voltage of - 0.5201 pu as shown in Fig. 9 and Fig. 10.

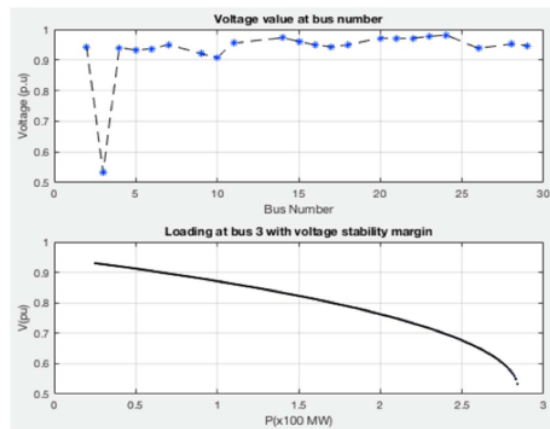

Fig.9 The loading graph on bus 3 approaches the critical point when the voltage has not collapsed

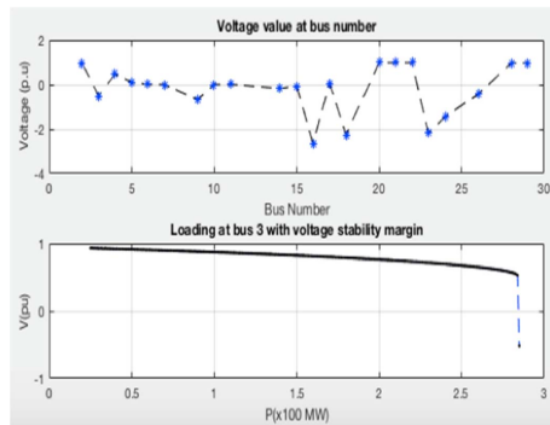

Fig.10 The loading graph on bus 3 when the voltage collapsed

## V. CONCLUSION

This paper presents a study regarding the using of the Artificial Bee Colony algorithm to solve the DED problem for the 150 kV Suselbar electric system in Indonesia. It is concluded that the proposed algorithm can solve the DED problem for the observed system. Obtained results are better than the using of the Lagrange method with a cost difference of 87,430 IDR/hour. Other results for L index stability, can

determine the location of buses that are critical in the system which has the smallest voltage value namely, bus 26 (bus Makale) for power limits constraint and bus 3 (bus Panakukang) for power limits and ramp rate constraint. The loading margin is reached when the power is 284 MW where the voltage on the bus (bus 3) nearly collapses.

## References

- [1] H. Saadat, *Power System Analysis*. Singapore: McGraw-Hill Series in Electrical and Computer Engineering, 1999.
- [2] Z. Jizhong, "Optimization of power system operation," *J. Chem. Inf. Model.*, vol. 53, no. 9, pp. 1689–1699, 2013.
- [3] S. G. Gaurav Kumar Gupta, "Particle Swarm Intelligence based Dynamic Economic Dispatch with Daily Load Patterns Including Valve Point Effect," *IEEE*, pp. 83–87, 2017.
- [4] S. F. M. Manjusha, "Multi objective dynamic economic dispatch with cubic cost functions," *Int. Res. J. Eng. Technol.*, vol. 3, no. 6, pp. 692–701, 2016.
- [5] E. E. H. Z. Zakaria, T. K. A. Rahman, "Economic Load Dispatch via an Improved Bacterial Foraging Optimization," *IEEE*, no. March, pp. 380–385, 2014.
- [6] Y. S. A. Ansar Suyuti, Ikhlas Kitta, "The impact of the operation planning of power plants for environmental emissions in south sulawesi," *ARNP J. Eng. Appl. Sci.*, vol. 12, no. 11, pp. 3440–3444, 2017.
- [7] I. C. G. Mustadir Darusman B, Ansar Suyuti, "Small signal stability analysis of wind turbine penetration suselbar interconnection system," 2018.
- [8] A. K. Nurlita Gamayanti, Abdullah Alkaff, "Optimisasi Dynamic Economic Dispatch Menggunakan Algoritma Artificial Bee Colony," *JAVA J. Electr. Electron. Eng.*, vol. 13, no. 1, pp. 23–28, 2015.
- [9] A. J. Wood, B. F. Wollenberg, and G. B. Sheble, *Power generation, operation, and control - Third edition*. 2014.
- [10] M. Peter Musau, "Multi Objective Dynamic Economic Dispatch with Cubic Cost Functions," *Int. J. Energy Power Eng.*, vol. 4, no. 3, p. 153, 2015.
- [11] S. Farook and M. Manjusha, "Optimization of Multi-Objective Dynamic Economic Dispatch Problem Using Knee Point Driven Evolutionary Algorithm," *Int. Electr. Eng. J.*, vol. 7, no. 10, pp. 2396–2402, 2017.
- [12] D. Karaboga and B. Basturk, "Artificial Bee Colony (ABC) Optimization Algorithm for Solving Constrained Optimization Problems," *Found. Fuzzy Log. Soft Comput.*, pp. 789–798, 2007.
- [13] R. A. Rasyid, "Optimization of 150 kV Suselbar Power Generation System With Integration Sidrap Wind Power Plant," Hasanuddin University, 2018.
- [14] I. C. G. Steven Humena, Salama Manjang, "Optimization Economic Power Generation Using Modified Improved PSO Algorithm Methods," *J. Theor. Appl. Inf. Technol.*, vol. 93, no. 2, pp. 522–530, 2016.

# Dynamic Economic Dispatch for 150 kV Sulsebar Power Generation Systems Using Artificial Bee Colony Algorithm

## ORIGINALITY REPORT

7%

SIMILARITY INDEX

3%

INTERNET SOURCES

7%

PUBLICATIONS

%

STUDENT PAPERS

## PRIMARY SOURCES

- 1 S. Hemamalini. "Dynamic economic dispatch using artificial bee colony algorithm for units with valve-point effect", European Transactions on Electrical Power, 2010  
Publication 1%
- 2 [ieeexplore.ieee.org](http://ieeexplore.ieee.org)  
Internet Source 1%
- 3 Dervis Karaboga, Bahriye Basturk. "A powerful and efficient algorithm for numerical function optimization: artificial bee colony (ABC) algorithm", Journal of Global Optimization, 2007  
Publication 1%
- 4 Moses Peter Musau. "Multi Objective Dynamic Economic Dispatch with Cubic Cost Functions", International Journal of Energy and Power Engineering, 2015  
Publication 1%
- 5 [repository.poliupg.ac.id](http://repository.poliupg.ac.id)  
Internet Source 1%

6

1library.net

Internet Source

1 %

7

Tanimoto, M.. "Advanced economic dispatching control algorithm using dynamic unit model and interior point method", Electric Power Systems Research, 19980901

Publication

1 %

8

Tuncay Ozcan, Sakir Esnaf. "A heuristic approach based on artificial bee colony algorithm for retail shelf space optimization", 2011 IEEE Congress of Evolutionary Computation (CEC), 2011

Publication

1 %

9

Diana Marcela Devia Narvaez, German Correa Velez, Diego Fernando Devia Narvaez. "Application of the gradient method in the economic dispatch", Contemporary Engineering Sciences, 2018

Publication

1 %

Exclude quotes

Off

Exclude matches

< 1%

Exclude bibliography

On